

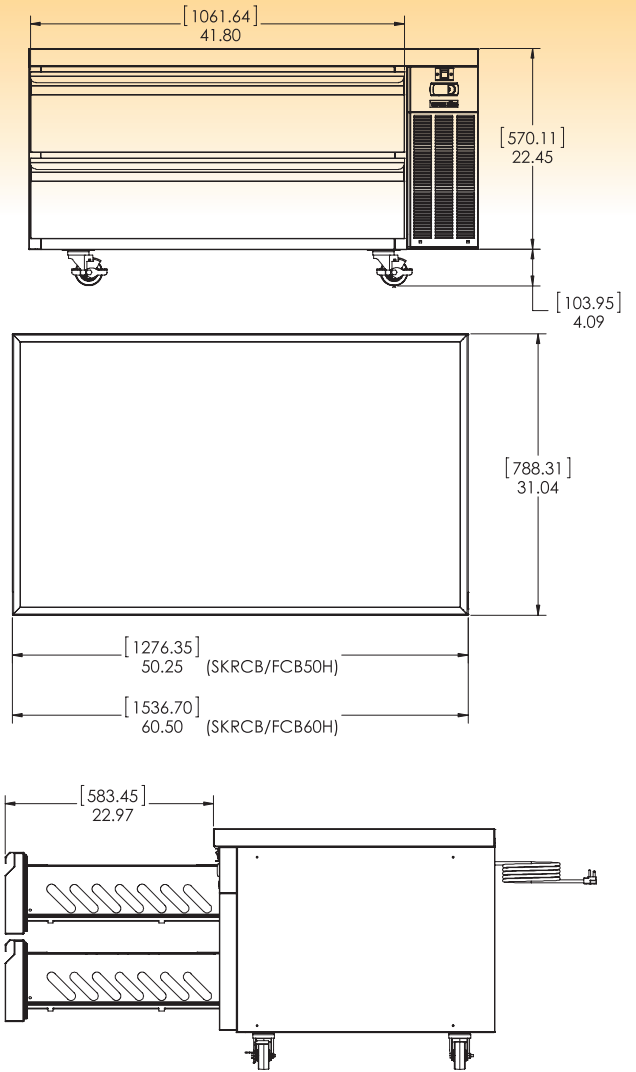

# Refrigerated Chef Base

MODEL SKRCB50H/C10



MODEL	LENGTH	DEPTH	HEIGHT	COMPRESSOR	AMPS	WEIGHT
SKRCB50H/C10	50.25"	31.04"	26.54"	1/4 HP	3.1	390 lbs.

<b>EXTERIOR</b>	Stainless steel, galvanized back.
<b>INTERIOR</b>	Aluminum. Coved corners and finished edges for ease of cleaning.
<b>INSULATION</b>	Environmentally friendly foamed-in-place polyurethane for maximum strength and durability.
<b>DRAWERS</b>	Full extension drawers with drawer slides welded to 12-gauge stainless steel framework. This premier slide and framework construction promotes lateral stability while offering high dynamic load capacities and a stay-shut feature. All drawers accom modate full size 12" x 20" x 6" deep hotel pans and 6" deep fractional pans. Drawers lift out for cleaning.
<b>REFRIGERATION</b>	CFC-free, 134a refrigerant, hermetically sealed, high efficiency, self contained refrigeration system.
<b>LISTINGS</b>	ETL Safety (U.S. and Canada), ETL Sanitation.
<b>WARRANTY</b>	One year parts and labor. Five year warranty on heavy duty drawer assemblies and compressor.



1600 Xenium Lane North  
 Minneapolis, MN 55441-3787  
 Phone (763) 923-2441  
 Fax (763) 553-1209  
[www.silverking.com](http://www.silverking.com)



Specifications subject to change without notice.

7/2013  
 © Silver King 2013  
 Printed in U.S.A.