



Click here to buy now!



1-866-285-1252

Project \_\_\_\_\_

Item \_\_\_\_\_

Quantity \_\_\_\_\_

FCSI section \_\_\_\_\_

Approval \_\_\_\_\_

Date \_\_\_\_\_

C4eT 6.20 ES

# Combi steamer

## Model

Convotherm 4 easyTouch

- easyTouch
- 7 slide rails
- Electrical
- Injection/Spritzer
- Right-hinged door



## Key features

- ACS+ operating modes: Steam, combi-steam, hot air
- ACS+ extra functions:
  - Crisp&Tasty - 5 moisture-removal settings
  - BakePro - 5 levels of traditional baking
  - HumidityPro - 5 humidity settings
  - Controllable fan - 5 speed settings
- easyTouch 9" full-touch screen
- ConvoClean+ fully automatic cleaning system with eco, regular and express modes - with optional single-dose dispensing
- Ethernet interface (LAN)
- HygienicCare
- USB port integrated in the control panel
- TriColor indicator ring - indicates the current operating status
- Steam generated by injecting water into the cooking chamber
- Right-hinged door

## Standard features

- ACS+ (Advanced Closed System +) operating modes:
  - Steam (86-266°F) with guaranteed steam saturation
  - Combi-steam (86-482°F) with automatic humidity adjustment
  - Hot air (86-482°F) with optimized heat transfer
- HygienicCare - food safety provided by antibacterial surfaces:
  - easyTouch control panel
  - Door handle and recoil hand shower
- easyTouch user interface:
  - 9" full-touch screen
  - Press&Go - automatic cooking with quick-select buttons
  - TrayTimer - oven-load management for different products at the same time
  - Regenerate+ - flexible multi-mode retherm function
  - ecoCooking - energy-save function
  - Low-temperature cooking / Delta-T cooking
  - Cook&Hold - cook and hold in one process
  - 399 cooking profiles each containing up to 20 steps
  - On-screen help with topic-based video function
  - Start-time preset
- Multi-point core temperature probe
- Door handle with safety latch and slam function
- Data storage for HACCP and pasteurization figures
- Preheat and Cool down function

## Options

- Steam and vapor removal – built-in condenser (upon request)
- Disappearing door – more space and added safety (see page 2)
- ConvoGrill with grease management function (upon request)
- ConvoSmoke - built in food-smoking
- Marine version (see separate data sheet)
- Available in various voltages
- Sous-vide probe, external connection
- Core temperature probe, external connection

## Accessories

- ConvoLink HACCP and cooking-profile management PC software
- Signal tower - indicates the operating status from a distance
- Banquet system (optionally as a package or individually): Plate rack, mobile shelf rack, transport trolley, thermal cover
- Equipment stands in various sizes and designs
- Racks for cooking and baking
- Stacking kits
- Cleaning products for the fully automatic ConvoClean+ cleaning system and the semi-automatic cleaning system



## Front view

(disappearing door optional)

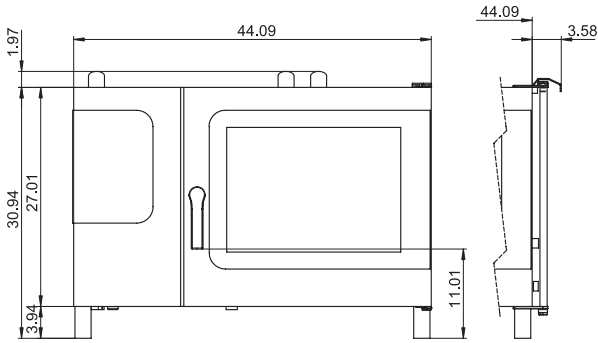

## Connection positions

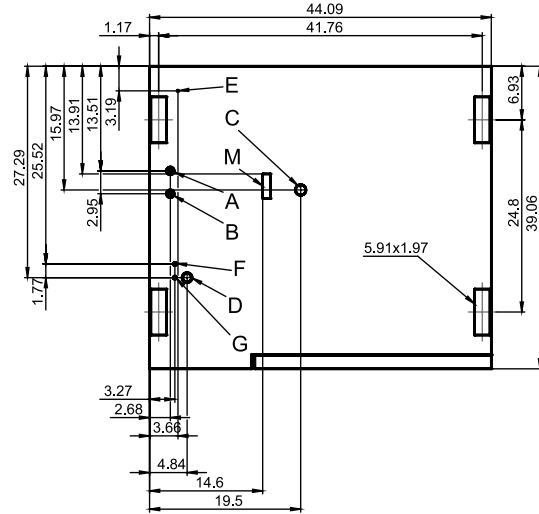

- A** Water connections (for water injection)
- B** Water connections (for cleaning, recoil hand shower)
- C** Drain connection (2" I. D.)
- D** Electrical connection
- E** Electrical ground
- F** Rinse-aid connection
- G** Cleaning-agent connection
- H** Air vent (2" I. D.)
- I** Ventilation port
- M** Safety overflow 3.2" x 1"

## View from above with wall clearances

(disappearing door optional)

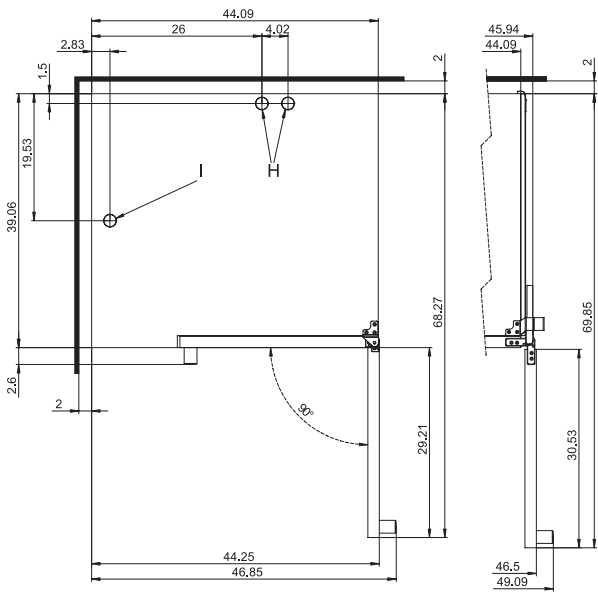

## Dimensions and weights

### Dimensions including packaging

Width x Height x Depth 53" x 39.8" x 44.9"

### Weight

Net weight without options\* / accessories 366 lbs  
Packaging weight 66 lbs

### Safety clearances\*\*

Rear 2"  
Right (right-hinged door) 2"  
Right (disappearing door pushed back) 5"  
Left (18" clearance recommended for service) 2"  
Top\*\*\* 20"

\* Max. weight of options: 42 lbs.

\*\* Minimum clearance from heat sources: 20".

\*\*\* Depends on the type of exhaust system and the ceiling's characteristics.

## Installation requirements

Max. absolute appliance inclination during operation\* max. 2° (3.4%)

\* Adjustable appliance feet as standard.

## Loading capacity

### Max. number of food containers

[Unit has 7 slide rails; rail spacing 2.68" max.]

Steam table pans (12"x20"x1")	12
Steam table pans (12"x20"x2.5")	12
Wire shelves, full size (20"x26")	6
Sheet pans, full size (18"x26")*	6
Sheet pans, half size (12"x20")*	12
Frying baskets, half size (12"x20")	12
Plates (optional plate rack)	27

### Max. loading weight

Per combi steamer	132 lbs
Per shelf level	33 lbs

\* Wire shelves required.

## Electrical supply

### 208V 3PH 60Hz / 240V 3PH 60Hz \*

Rated power consumption	15.9 / 21.0 kW
Rated current	44.1 / 50.6 A
Power supply wire gauge	6 AWG
Conductor insulation rating	194°F / 90°C

### 440V 3PH 60Hz / 480V 3PH 60Hz \*

Rated power consumption	16.3 / 19.3 kW
Rated current	21.4 / 23.3 A
Power supply wire gauge	8 AWG
Conductor insulation rating	194°F / 90°C

When using the ConvoSmoke option, the only available voltage options are:

### 208V 3PH 60Hz \*

Rated power consumption	15.9 kW
Rated current	44.1 A
Power supply wire gauge	6 AWG
Conductor insulation rating	194°F / 90°C

### 240V 3PH 60Hz \*

Rated power consumption	21.0 kW
Rated current	50.6 A
Power supply wire gauge	6 AWG
Conductor insulation rating	194°F / 90°C

\* Prepared for connection to an energy optimizing system.

## Water connections

### Water supply

Water supply	Two 3/4" I. D. GHT-M (garden hose adapter). The appliance is designed for a permanent hookup to the water supply that uses a connecting hose with a minimum diameter of 1/2"
Flow pressure	22 - 87 PSI / 1.5 - 6 bar

### Drain

Drain version	Permanent hookup (recommended) or funnel waste trap
Type	2" I. D. (comes elbow-shaped as standard)
Slope for drainpipe	min. 3.5% (2°)

## Water quality

### Water connection A\* for water injection

General requirements	Drinking water, typically treated water (install a water treatment system if necessary)
TDS	70 - 125 ppm
Hardness	70 - 125 ppm (4 - 7 gpg)

### Water connection B\* for cleaning, recoil hand shower

General requirements	Drinking water, typically untreated water
TDS	70 - 360 ppm
Hardness	70 - 360 ppm (4 - 21 gpg)

### Water connections A, B\*

pH value	6.5 - 8.5
Cl <sup>-</sup> (chloride)	max. 60 ppm
Cl <sub>2</sub> (free chlorine)	max. 0.2 ppm
SO <sub>4</sub> <sup>2-</sup> (sulfate)	max. 150 ppm
Fe (iron)	max. 0.1 ppm
SiO <sub>2</sub> (silica)	max. 13 ppm
NH <sub>2</sub> Cl (monochloramine)	max. 0.4 ppm
Temperature	max. 104°F / max. 40°C

\* See connection positions diagram, p. 2.

NOTICE: The owner/operator/purchaser must ensure that the water quality requirements are met. Otherwise the original equipment warranty is void.

**Emissions**

**Water consumption**

**Accessories**

**Emissions**

**Heat emission**

Latent	3400 BTU/h
Sensitive	4300 BTU/h

<b>Drain temperature</b>	max. 140°F / 60°C
--------------------------	-------------------

<b>Decibel rating</b>	max. 70 dBA
-----------------------	-------------

**Water consumption**

**Water connection A\***

Average consumption for cooking	1.35 gph
Required flow rate	0.16 gpm

**Water connections A, B**

Average consumption for cooking**	2.01 gph
Required flow rate	3.96 gpm

\* Values intended as guide for specifying the water treatment system.

\*\* Incl. water required for cooling the wastewater.

NOTICE: See connection positions diagram, p. 2.

**Please note:**

- Please refer to the Installation manual for further technical data and for instructions on installation and setup.
- Convotherm reserves the right of design improvement or modification, as warranted.
- There are numerous federal, national and local laws, regulations and standards. It is the responsibility of the owner and installer to observe these laws, regulations and standards (e.g. fire regulations and health and safety standards).
- Convotherm combi steamers are built to comply with the applicable standards for manufacturers.

**ACCESSORIES**

(For more detailed information, please refer to the Accessories brochure.)

**Stacking kit**

Combinations allowed	6.20 on 6.20
	6.20 on 10.20

**If combining two electrical units**

Select the "stacking kit for Convotherm 4 electrical units"

**If combining one electrical unit and one gas unit in a stacking kit**

Select the "stacking kit for Convotherm 4 electrical units" if:

Bottom combi steamer	EB/ES
Top combi steamer	GB/GS

Select the "stacking kit for Convotherm 4 gas units" if:

Bottom combi steamer	GB/GS
Top combi steamer	EB/ES

**Equipment stand**

Standard support surface height	26.38"
---------------------------------	--------

9758232\_04 ENG\_USA 05/15. © 2015 Manitowoc. Please note that the product is being continuously improved and that, as a result, these specifications are subject to change without notice.