



New
**STAR-MAX® GAS GRIDDLES WITH
THERMOSTATIC CONTROL AND SAFETY PILOT**
Models 624TSPF, 636TSPF & 648TSPF

Features/Benefits:

- ★ *NEW* throttling thermostat inserted into the griddle plate 5/16" from the cooking surface, adjusts from 150° to 450°F providing quick response to surface temperature change.
- ★ Available in 24", 36" and 48" widths to meet your space and volume requirements.
- ★ *NEW* highly polished 1" thick polished steel plate for superior heat distribution, fast recovery and energy efficient operation.
- ★ "U"-shaped 28,300 BTU aluminized steel burner every 12" of cooking surface provides even heat distribution and maximum performance.
- ★ *NEW* longer lasting, heavy-duty metal knobs.
- ★ An automatic safety pilot for each burner for safe and easy operation.
- ★ Heavy-duty body construction with stainless steel front, side panels, bull nose and 4-1/2" high tapered splash guard.
- ★ Spatula wide 3-1/4" front grease trough and grease chute for easy cleaning.
- ★ Double wall construction and enclosed bottom helps reduce heat loss.
- ★ Cool-to-the-touch stainless steel bull nose front provides knob protection and comfortable work zone.
- ★ Large 4-1/2 quart stainless steel grease drawer.
- ★ Gas convertible in the field with conversion kit supplied. Units are shipped Natural Gas.
- ★ Heavy-duty 4" adjustable legs to fit your countertop line-up requirements.



Model 648TSPF

Applications:

For breakfast, lunch or dinner, Star-Max throttling thermostatic griddles provide flexibility for a variety of menu items.

Quality Construction:

Star-Max® griddles feature 1" thick polished steel griddle plate 4-1/2" high wrap-around stainless steel splash guard and 3-1/4" wide front access grease trough with 4-1/2 quart grease drawer capacity. Includes a 28,300 BTU aluminized burner every 12" of width controlled by a throttling thermostatic with safety pilot, 3/4" N.P.T. male gas connection with convertible pressure regulator, and 4" adjustable legs. These units are approved for installation within 6" of non-combustible surfaces. Griddles operate on Natural or Propane gas.

New
Warranty:

Star-Max® gas griddles are covered by Star's **TWO YEAR** parts and labor warranty.





Star Manufacturing

New
**STAR-MAX® GAS GRIDDLES WITH
 THERMOSTATIC CONTROL AND SAFETY PILOT**
Models 624TSPF, 636TSPF & 648TSPF

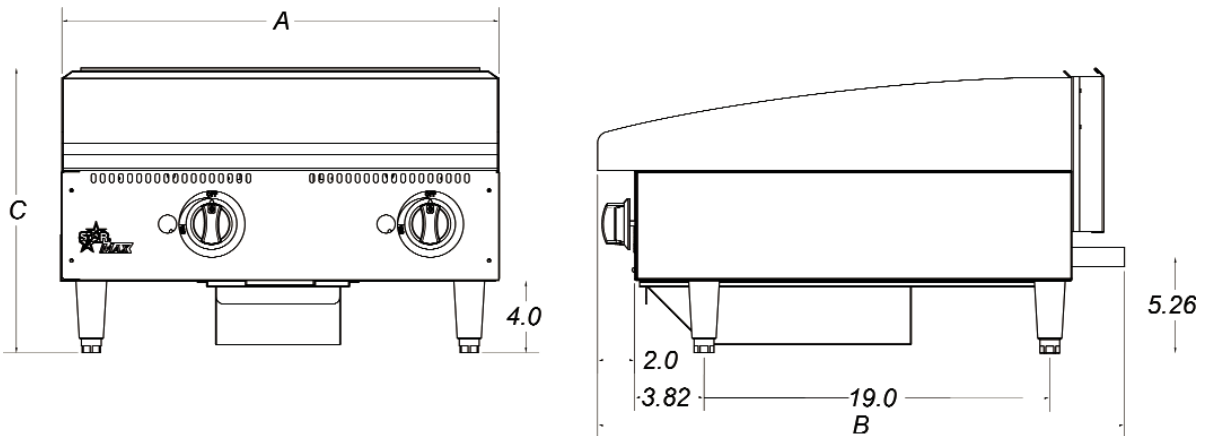

Specifications

Model No.	Dimensions				Number of Thermostats	BTU	Grid Area	Plate Thickness Inches (cm)	Weight	
	(A) Width Inches w(cm)	(B) Depth Inches (cm)	(C) Height Inches (cm)	(D) Leg Width Inches (cm)					Installed lbs. (kg)	Shipping lbs. (kg)
624TSPF	24 (61.0)	29 (73.7)	15-1/2 (39.4)	20-15/16 (52.7)	2	56,600	498 sq. in. 3213.1 sq cm	1 (2.5)	165 (74.8)	175 (79.4)
636TSPF	36 (91.4)	29 (73.7)	15-1/2 (39.4)	20-15/16 (52.7)	3	84,900	747 sq. in. 4819.6 sq cm	1 (2.5)	247 (112.0)	262 (118.8)
648TSPF	48 (121.9)	29 (73.7)	15-1/2 (39.4)	20-15/16 (52.7)	4	113,200	996 sq. in. 6426.2 sq cm	1 (2.5)	330 (149.7)	350 (159.0)

Units operate on Natural or Propane Gas.

Typical Specifications

Gas griddles are constructed with stainless steel panel and double wall aluminized steel side panels. Griddle plate is 1" (2.54 cm) thick, 4-1/2" high tapered wrap-around stainless steel splash guard come standard. Unit has a 3-1/4" (8.3 cm) wide front grease trough with grease chute and a 4-1/2 quart (4.26 L) stainless steel grease drawer. Unit is heated by 28,300 BTU aluminized steel burner for every 12" (30.5 cm) of griddle width and is controlled by a throttling type thermostat embedded into griddle plate. Thermostat knobs are protected by a stainless steel bull nose front. An automatic safety pilot is provided for each burner. Griddles are supplied with 4" (10.2 cm) high die cast nickel plated steel legs that have a 1-3/8" (3.5 cm) adjustment. Gas connection is 3/4" N.P.T. male and a convertible pressure regulator is provided. Units are approved for installation within 6" (15.2 cm) of combustible and non-combustible surfaces and are UL Gas certified and UI Sanitation listed. Printed in the U.S.A.

Due to periodic changes in designs, methods, procedures, policies and regulations, the specifications contained in this sheet are subject to change without notice. While Star Manufacturing exercises good faith efforts to provide information that is accurate, we are not responsible for errors or omissions in information provided or conclusions reached as a result of using the specifications. By using the information provided, the user assumes all risks in connection with such use.

Star Manufacturing - 10 Sunnen Drive - P.O. Box 430129 - St. Louis, MO 63143-3800
 Phone: (314) 678-6303 - FAX: (314) 781-5445 - www.star-mfg.com

Star-Max® Gas Griddles with Thermostatic Controls and Safety Pilot